



MEMORANDUM

April 10, 2014

TO: Health District Environmental Health Directors
Health District Land Based Supervisors
DEQ Regional Engineering Managers
DEQ Regional Office Administrators
DEQ Wastewater Program – State Office

FROM: Tyler R. Fortunati, R.E.H.S., On-Site Wastewater Coordinator

SUBJECT: Split Flows (IDAPA 58.01.03.007.15) – Interpretation and Guidance

This memorandum provides interpretation and guidance on Split Flows (IDAPA 58.01.03.007.15). This rule states that “The wastewater from a single building sewer or sewer line may not be divided and discharged into more than one septic tank or compartment.” Since plumbing configurations vary from structure to structure this memorandum provides a standardized approach to determining if a structure’s plumbing is in violation of IDAPA 58.01.03.007.15. All plumbing discussed within this memo is only in reference to wastewater plumbing.

Interpretation

Split flows, a violation of IDAPA 58.01.03.007.15, occurs when a building sewer is divided and discharged into parallel septic tanks. This may occur when:

- The building sewer is divided outside the structure’s foundation and the subsequent sewer lines discharge into different septic tanks, or
- Plumbing that is interconnected under a structure exits the structure in more than one location.

Plumbing that is isolated from all other plumbing within a structure and dedicated to a specific portion of the structure’s floor plan may discharge to an individual septic tank. A structure may have several septic tanks if the plumbing isolation requirement is met. The plumbing cannot be interconnected to plumbing associated with other areas of the structure’s floor plan that also contain a discharge point associated with a separate septic tank.

A structure with multiple septic tanks may have a single shared drainfield or more than one drainfield. This will be dependent upon required drainfield installation depths and system components. If more than one drainfield is installed for a single structure a health district may require separate subsurface sewage disposal permits for each drainfield. If there are multiple

septic tanks installed for a structure, but all of the septic tanks are connected to the same drainfield then only one subsurface sewage disposal permit is required.

If a structure's plumbing is proposed to exit the building foundation in more than one location a copy of the structure's plumbing plan should be obtained as part of the permit application (allowed under IDAPA 58.01.03.005.04.o). Additionally, upon inspection if it is noted that the structure's plumbing exits the foundation in more than one location and discharges to separate septic tanks, the health district should require a plumbing plan to ensure that the plumbing discharging to each tank serves different portions of the structure and are isolated from one another. Along with the plumbing plan the applicant should submit a floor plan for the structure so that the uses of the structure associated with each set of isolated plumbing can be determined for proper sizing of the septic tanks and associated drainfield/drainfields. The inspection of construction plans or as-built construction plans for any structure that is already constructed after a subsurface sewage disposal permit has been issued is allowed by IDAPA 58.01.03.011.01 (to ensure compliance with IDAPA 58.01.03.007 and 58.01.03.008).

Minimum Design Requirement Guidance

If an applicant proposes to install isolated wastewater plumbing for portions of a single structure the following requirements should be met:

- Each septic tank and associated drainfield must be sized for the isolated portions of the building's plumbing that are connected to the individual system based upon the sizing requirements of IDAPA 58.01.03.007 and 58.01.03.008 with the following minimum requirements:
 - The minimum size of each independent septic tank shall be 900 gallons (does not apply to septic tanks in series) for all residential systems regardless of whether bedrooms are connected to the isolated plumbing discharging to the septic tank or not.
 - All other tank sizing shall follow the requirements of IDAPA 58.01.03.007.
 - The minimum drainfield sizing of one bedroom or 150 gallons per day shall be used for all residential drainfields regardless of whether bedrooms are connected to the isolated plumbing discharging to the septic tank or not.
 - All other drainfield sizing shall follow the requirements of IDAPA 58.01.03.008.03.a.
- Enough room must be available for primary and replacement drainfields for each individual system installed on the property (IDAPA 58.01.03.008.03.c).

Examples

The following figures provide plumbing configuration examples. Figures 1 and 2 provide acceptable plumbing configurations that would not violate IDAPA 58.01.03.007.15. Figures 3 through 5 provide unacceptable plumbing configurations that would violate IDAPA

58.01.03.007.15. These figures may not cover every plumbing configuration that is encountered. Configurations not covered by this memorandum may be submitted to DEQ's On-Site Wastewater Coordinator for conformance with IDAPA 58.01.15.007.15 if necessary.

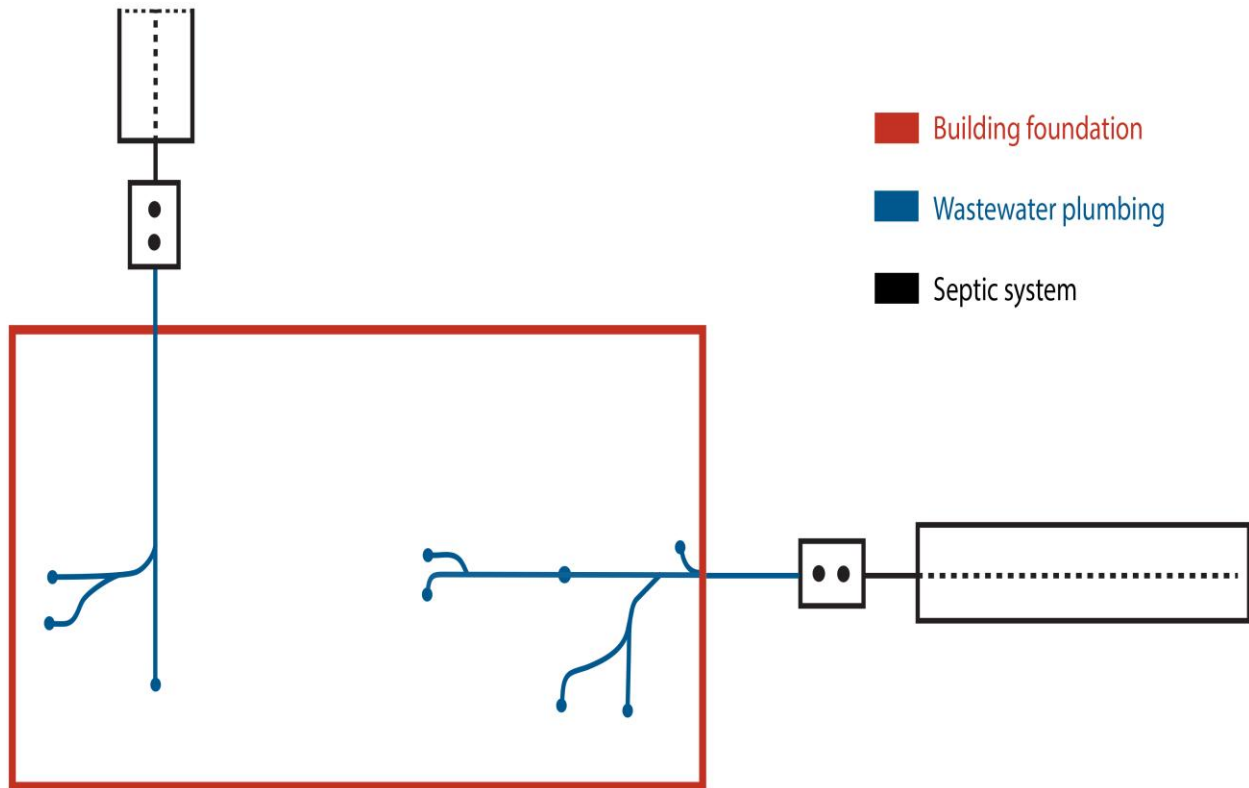

Figure 1: Acceptable plumbing configuration that does not violate IDAPA 58.01.03.007.15.

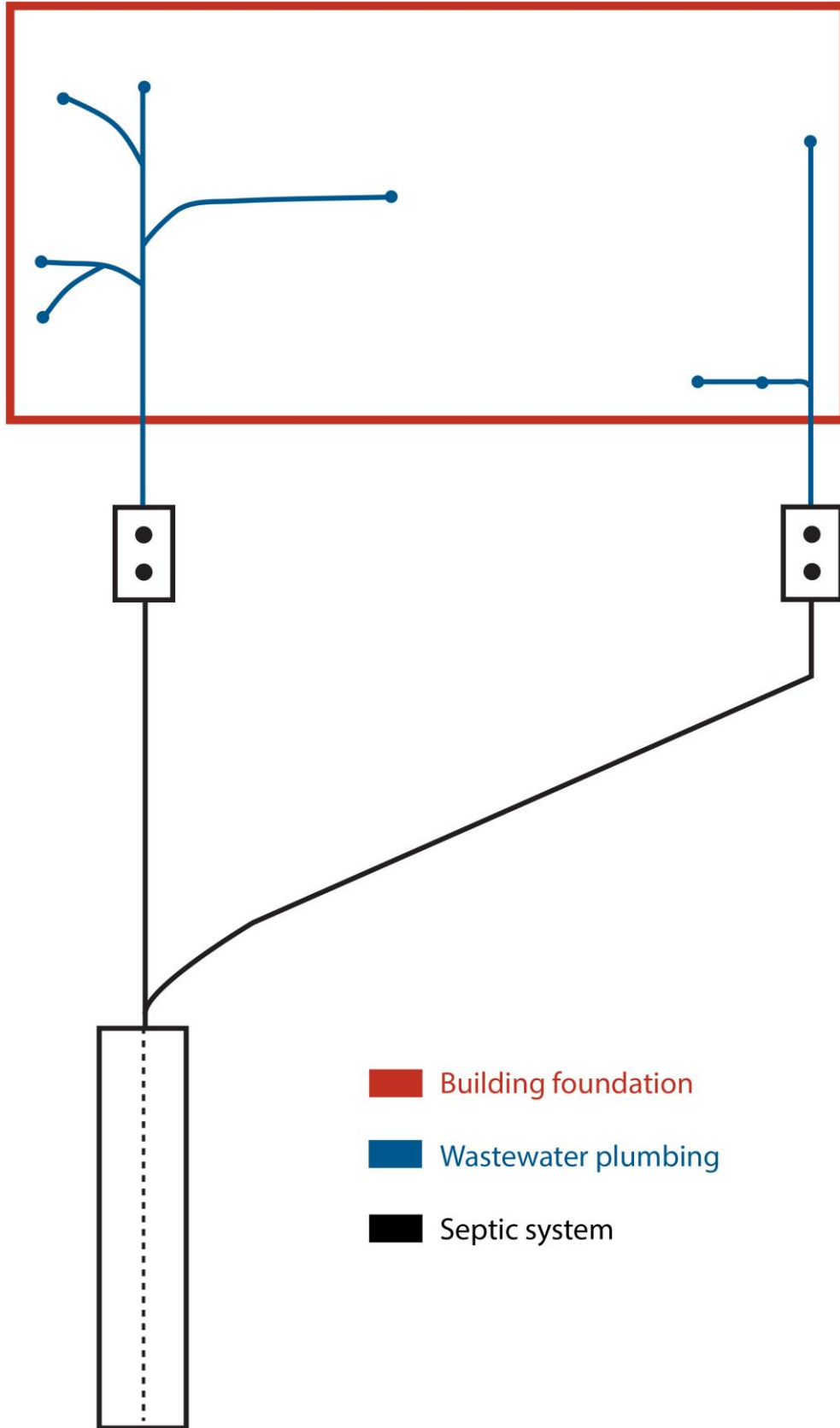

Figure 2: Acceptable plumbing configuration that does not violate IDAPA 58.01.03.007.15

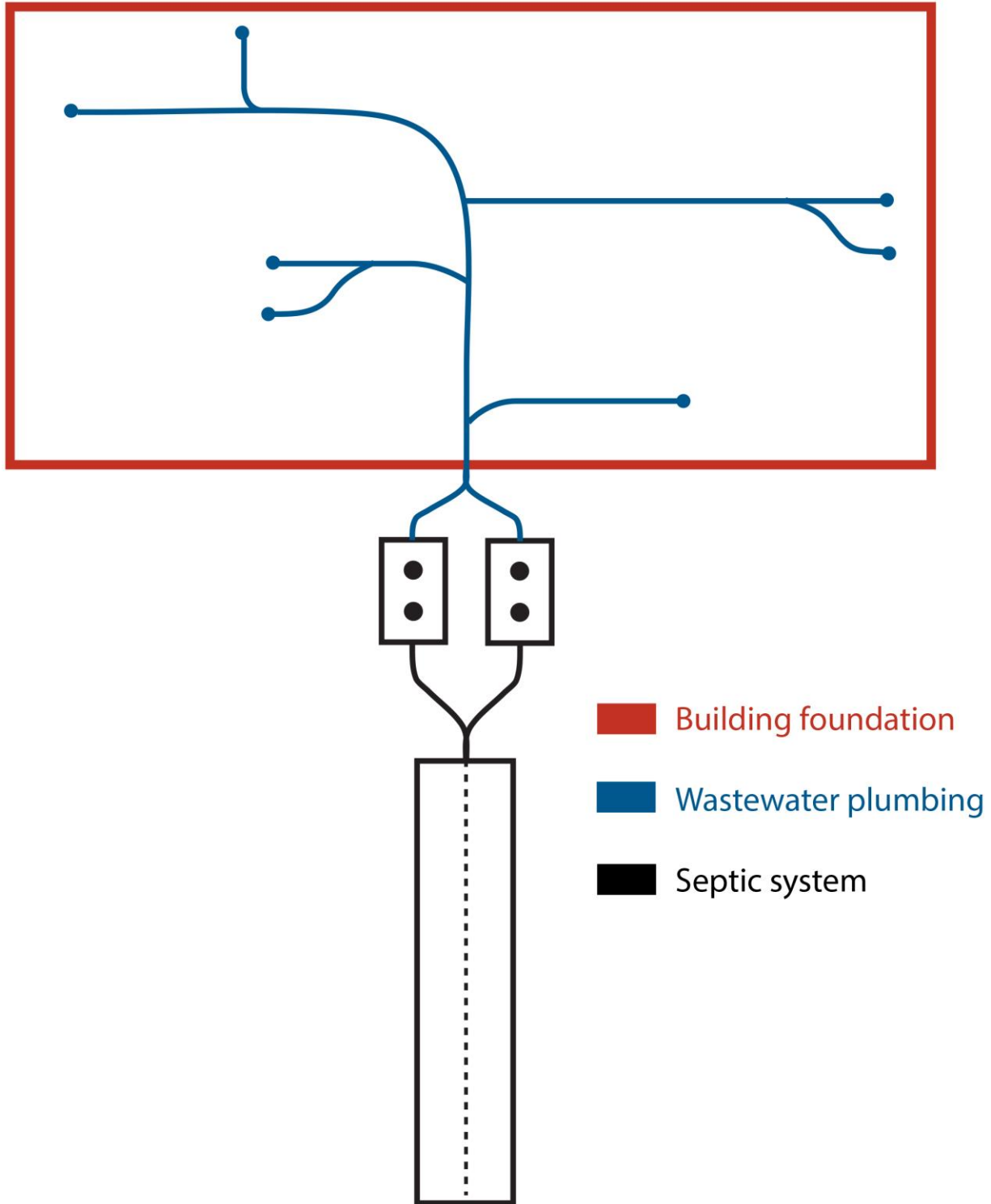

Figure 3: Unacceptable plumbing configuration that violates IDAPA 58.01.03.007.15.

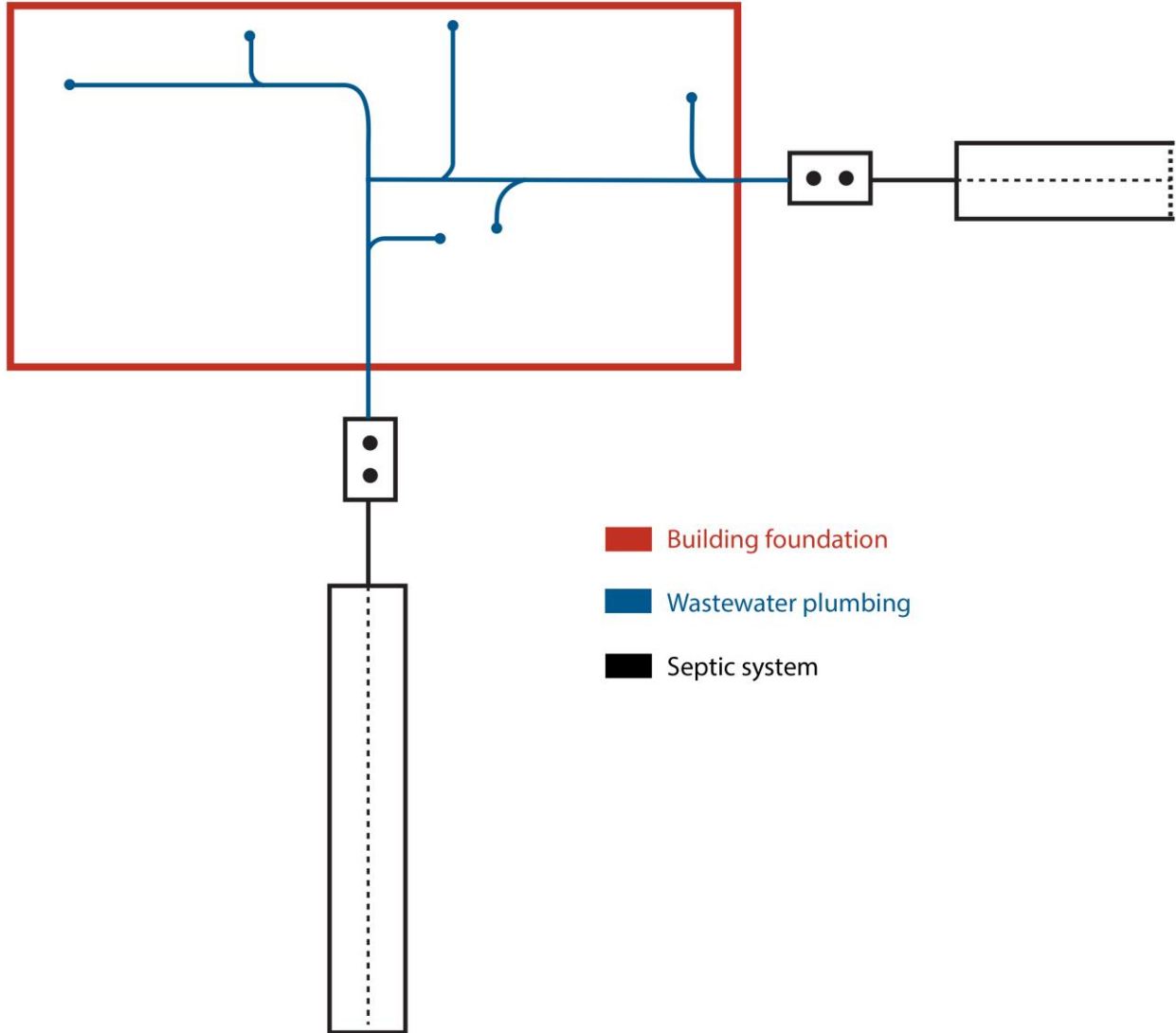

Figure 4: Unacceptable plumbing configuration that violates IDAPA 58.01.03.007.15.

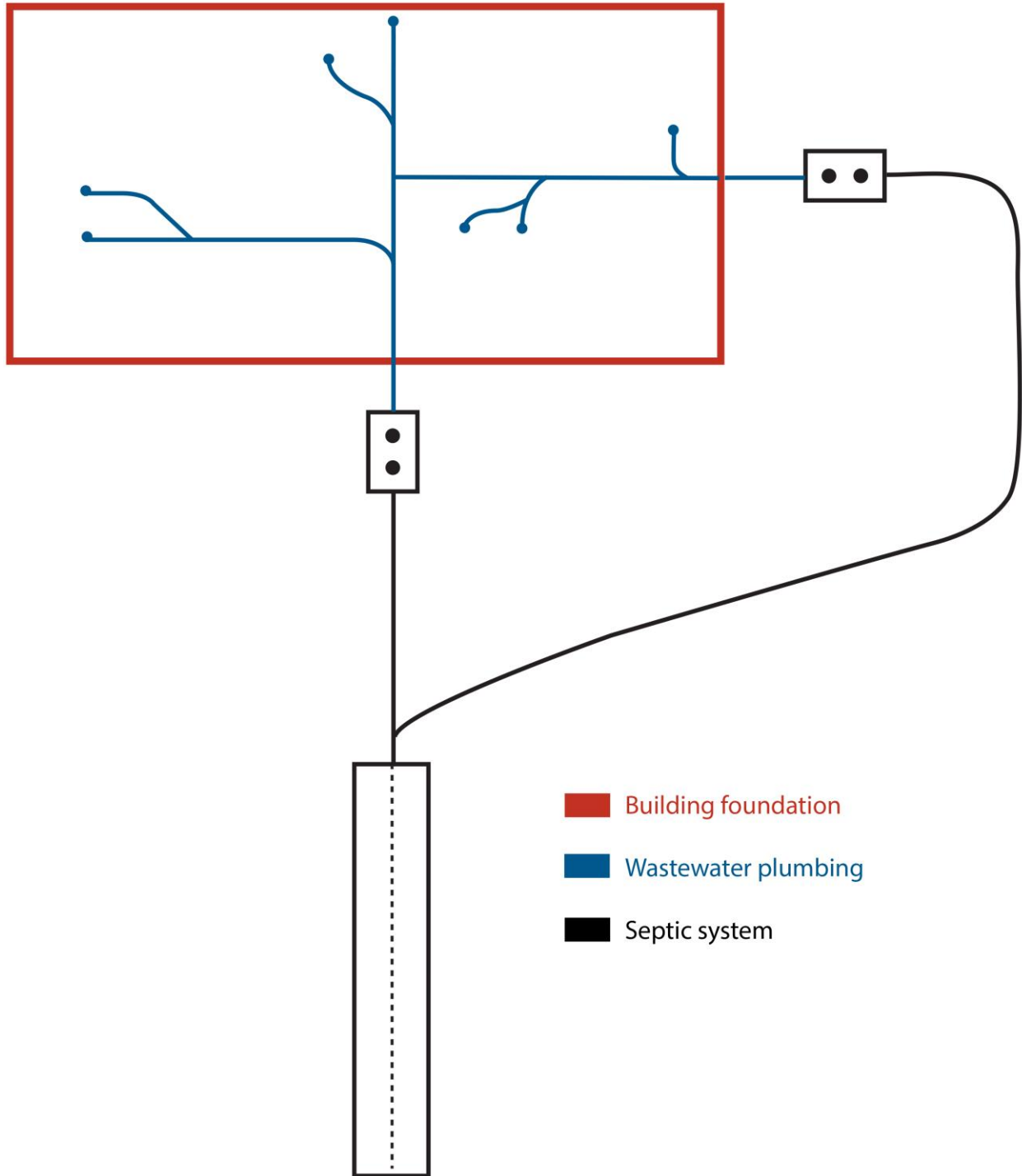

Figure 5: Unacceptable plumbing configuration that violates IDAPA 58.01.03.007.15.